

24th EWMD International Conference

# Innovation in Europe



# 24th EWMD International Conference

Claudia Schmitz

President EWMD International ev



# Innovation

## The first ideas and networking



Marion Diehr

Waltraut Ritter

Brigitte Ott-Goebel

Claudia Schmitz

Teresa Correia de Lacerda



# EWMD Corporate Members



# Siemens wants Diversity

- Löscher: „Siemens is white, male and German“  
But 70 % of the turnover is outside Germany



Jill Lee, **Chief Diversity Officer**  
Ex Siemens Finance Board in China

Appointed 3. November 2008





# Innovation

Economic view :

**Institutional creative destruction**

Josef Schumpeter 1934

**Schumpeterian view of capitalism as an engine of progressive change.**





# Lisbon Strategy 2000

In 2000, the "Lisbon Strategy" aims at making the EU the ***"most competitive and dynamic knowledge-based economy in the world by 2010, capable of sustainable growth, with more and better jobs and greater social cohesion"***.

2001 the Göteborg European Council decided to merge Lisbon with a **Sustainable Development strategy** and acknowledged the three complementary pillars of the Lisbon Strategy: **The economic, the social and the environmental pillar.**



# Goals changed

***Europe to become the most competitive and dynamic knowledge-based economy in the world by 2010, capable of sustainable growth***

***Europe needs Innovation and patents***

***Europe needs High Tech and Innovation***



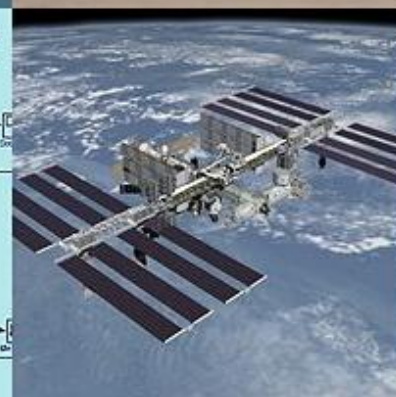
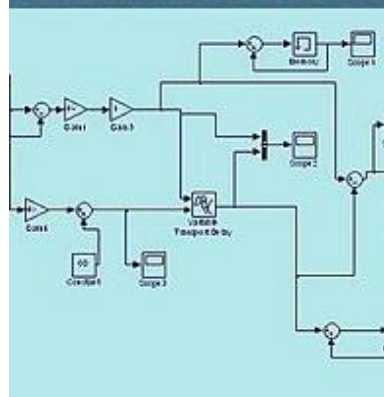
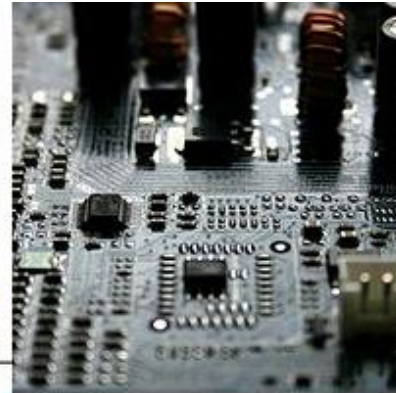
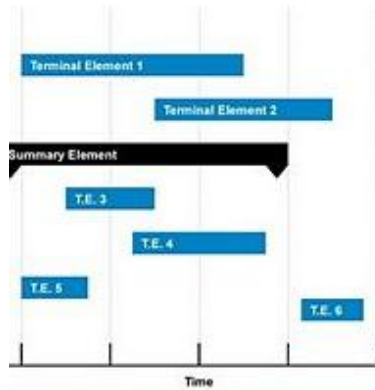

# Innovation in Production



# Innovators

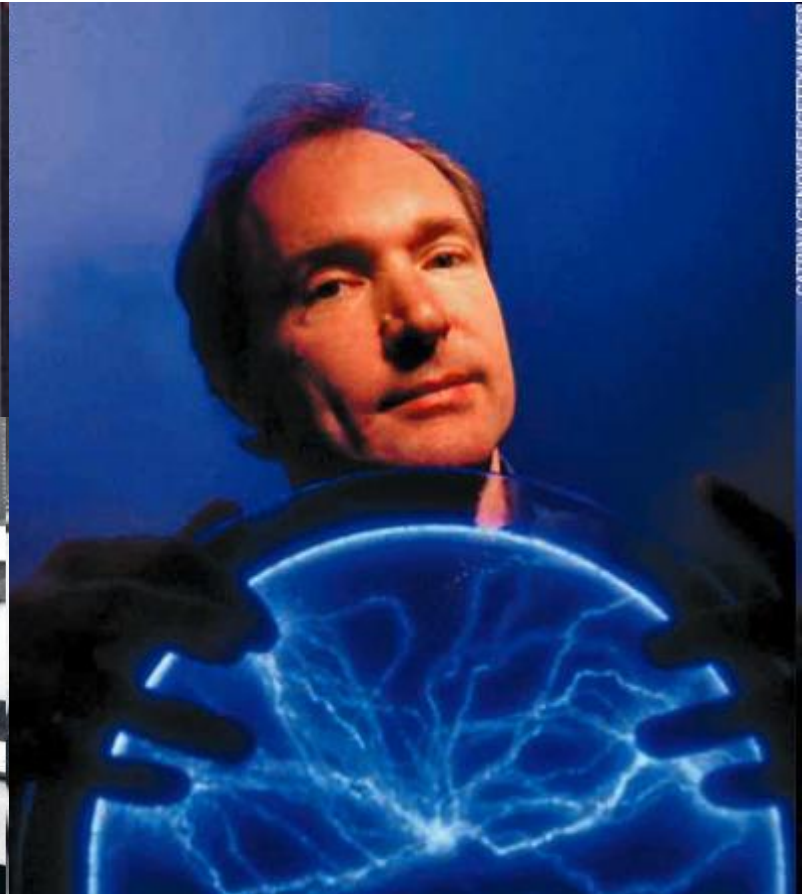

**EW**  
EMD



# constructivism

Innovation is what you believe it is .....

Thesis: **Innovation is driven by need**  
It is a gut-feeling that creates  
passion



# Activists



Margaret Sanger, New York



1960  
Enovid



**Trio**  
Margaret Higgins-Sanger  
Katharine Dexter McCormick  
Gregory Pincus

# Innovators



Marion Donovan  
Housewife  
New York

Patent 1951  
Nappies



# Josephine Cochrane



Cochrane Dishwasher  
patent in 1886

In 1893, Cochrane presented her machine at the Chicago World's Fair, where she won an award for its design and durability.

Cochrane's company became KitchenAid, part of the Whirlpool Corporation.

# Technology for Mobile Phones



Hedy Lamarr

Bluetooth  
WLANs  
UMTS

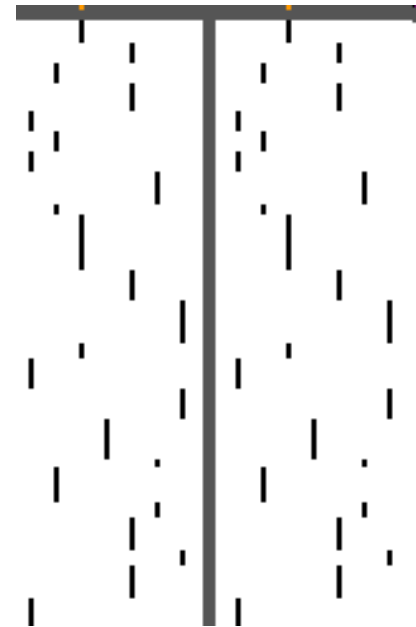

Frequency Hopping  
Spread Spectrum



# Innovation of Systems

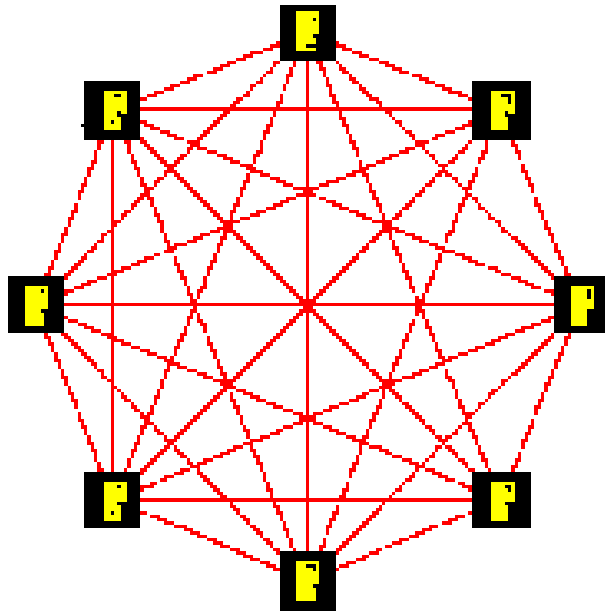

**EW**  
EMD

# Production System of Toyota

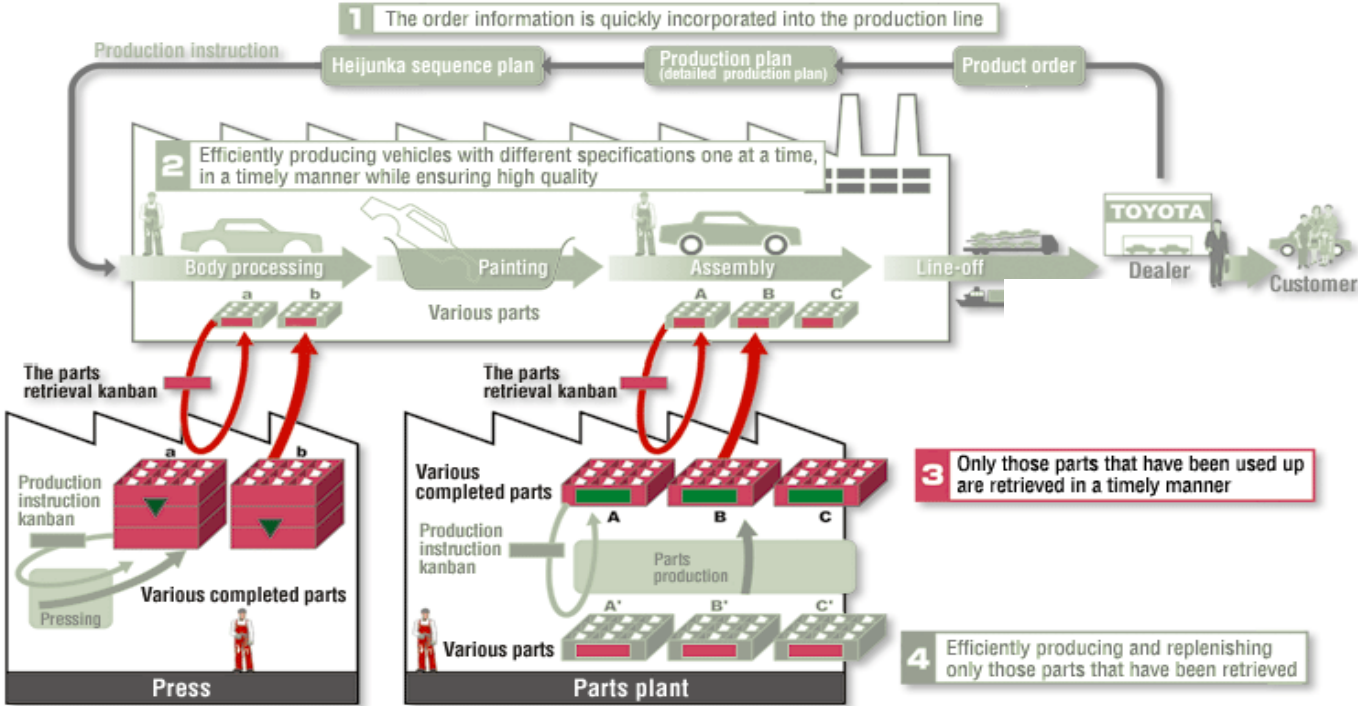

**1** Product order information is communicated to the production line

**2** Timely production

**3** Replacement of parts used

**4** Production of parts retrieved

# Innovation of Global Systems

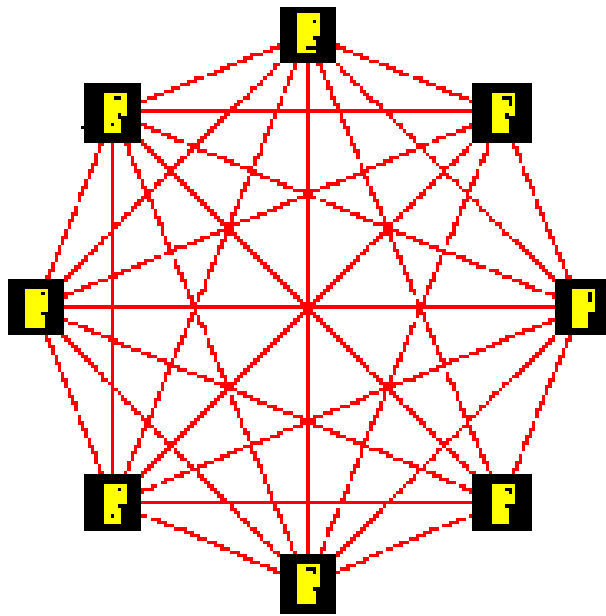

# Great System Thinker's

- In the 1970s **Stafford Beer** identifies self-organization in persisting and living systems.

In 1972 Chemist **Donella Meadows** was on the MIT team that produced the global computer model „World3“ for the Club of Rome and wrote the book [Limits to Growth](#).

- In 1984 Sociologist **Niklas Luhmann** published the social theory with the concept of self-referentiality of self-organization.



# Complexity is blocking minds

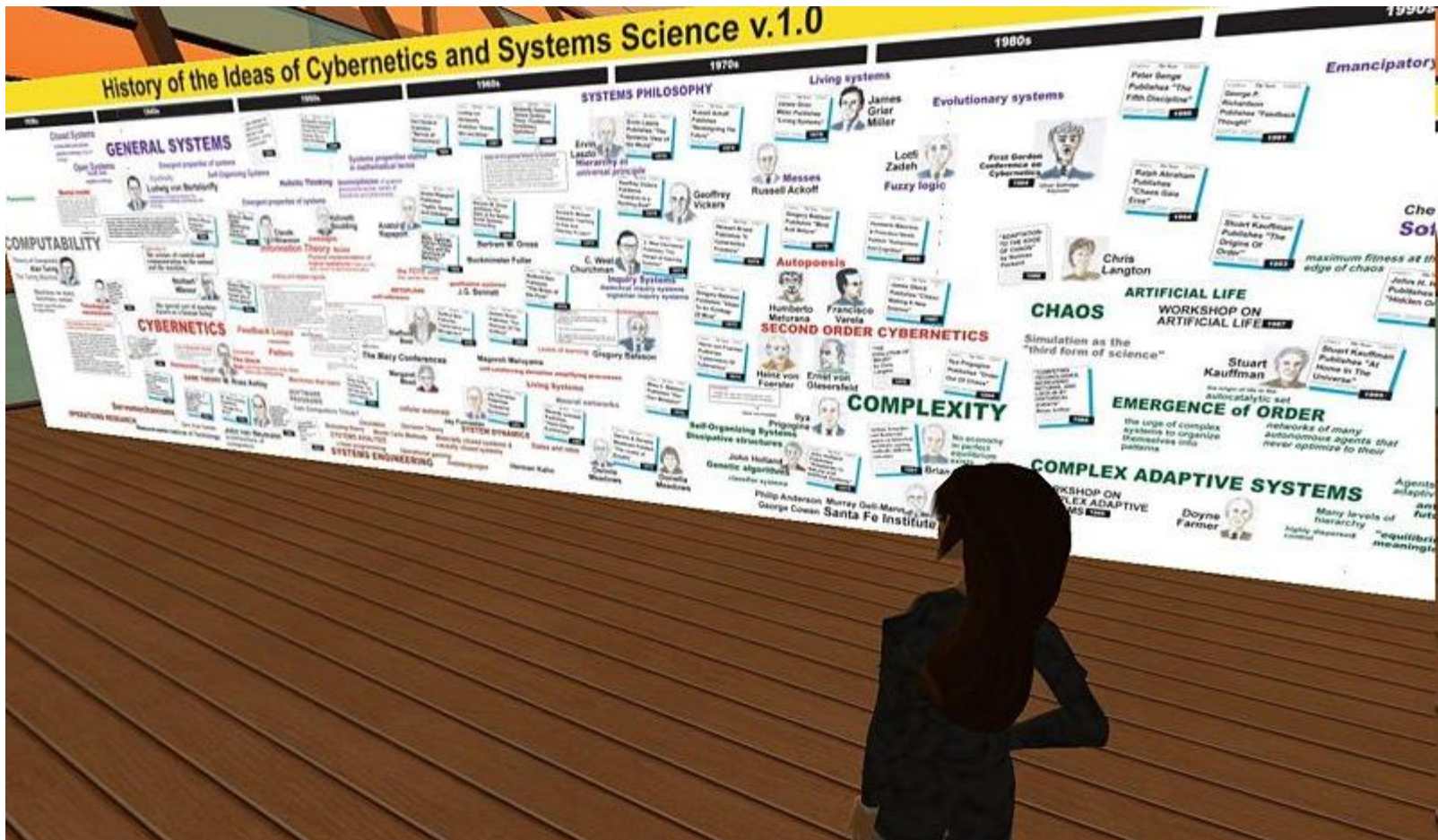

# Attention > Information > Memory > Decision

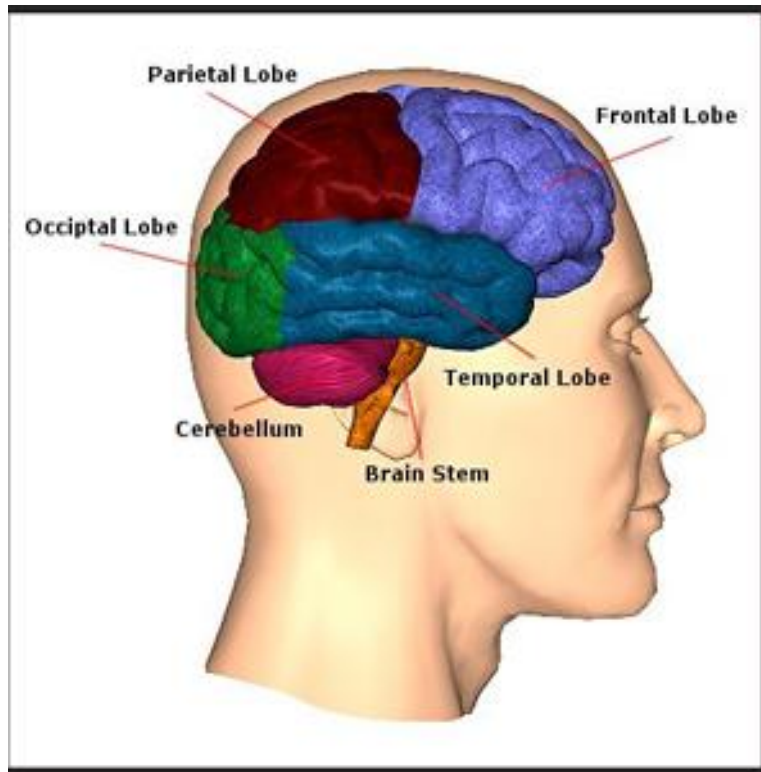

This theory was formulated in the 1880s for door-to-door salesman

**Decision making** can be regarded as an outcome of mental processes ([cognitive process](#)) leading to the selection of a course of action among several alternatives.

Humans are social living systems – the trigger is also group dynamic



# Innovation in Systems

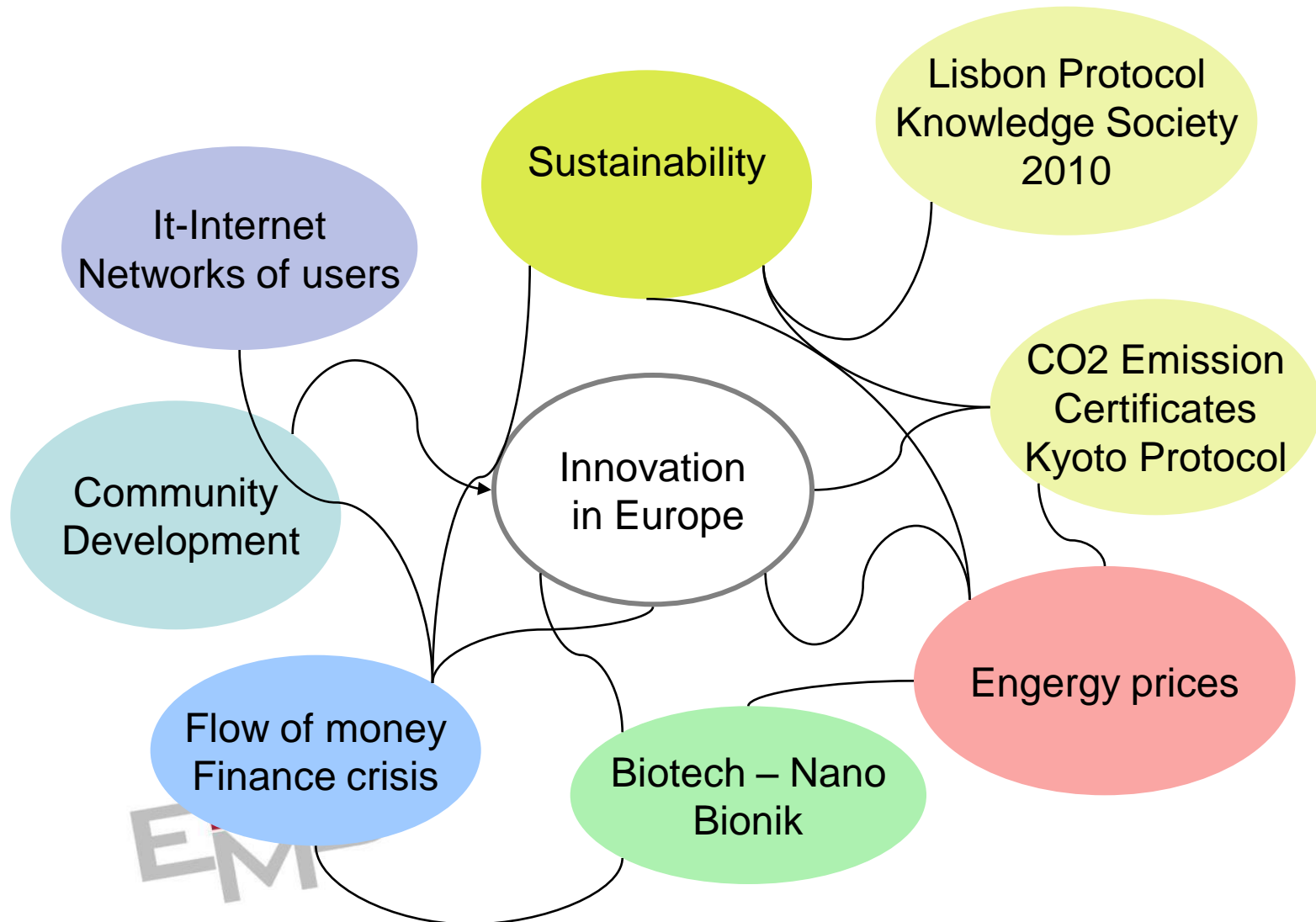

# Global Finance Systems



# Responsibility

It is the system

Study of Richard Sennett, Sociologist in US about the behaviour of the Wall Street Bankers.

It is the system

He gets the Gerda-Henkel-Award next Monday in Düsseldorf

I report to the system

I am part of the system



# Innovation in Management



Gary Hamel

„The Future of Management“

Build a company that gets the best out of your people !



<http://www.amazon.com/Future-Management-Bill-Breen/dp/1422102505>

# Leadership European Style?

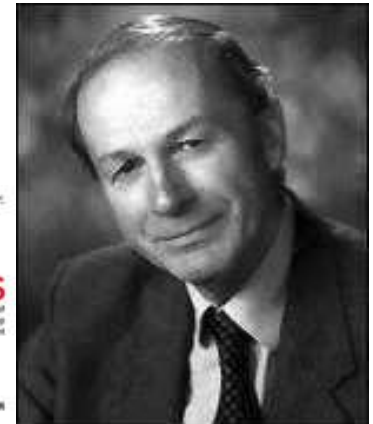
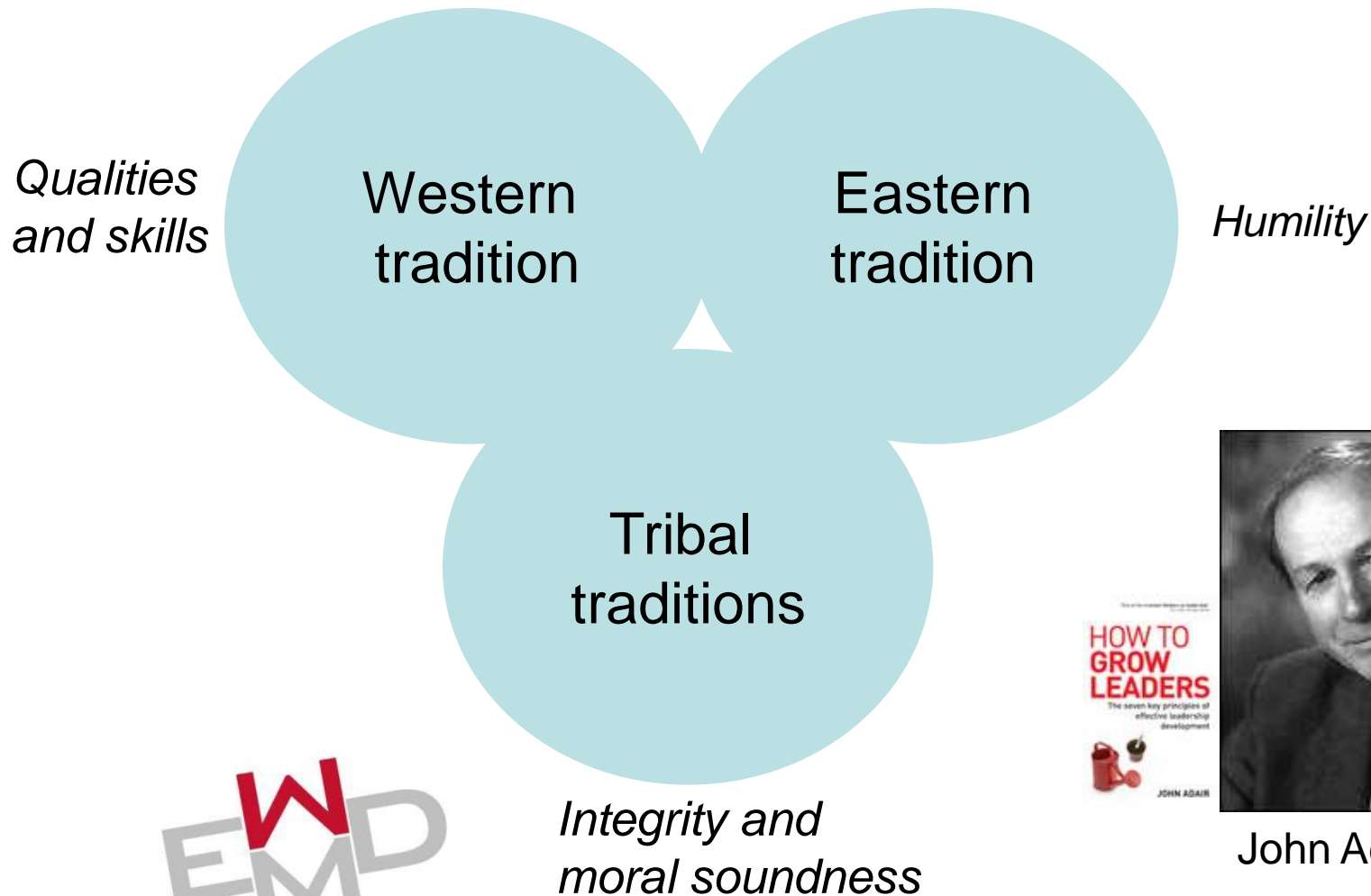

John Adair, UK

# Why do we need Innovation?



# The 4 Pillars of the conference

Social Innovation

Technical Innovation

Innovation in Leadership

Innovation in Emerging Markets



# Science - Bionics



# Emerging Markets



# IT – Networks - Internet

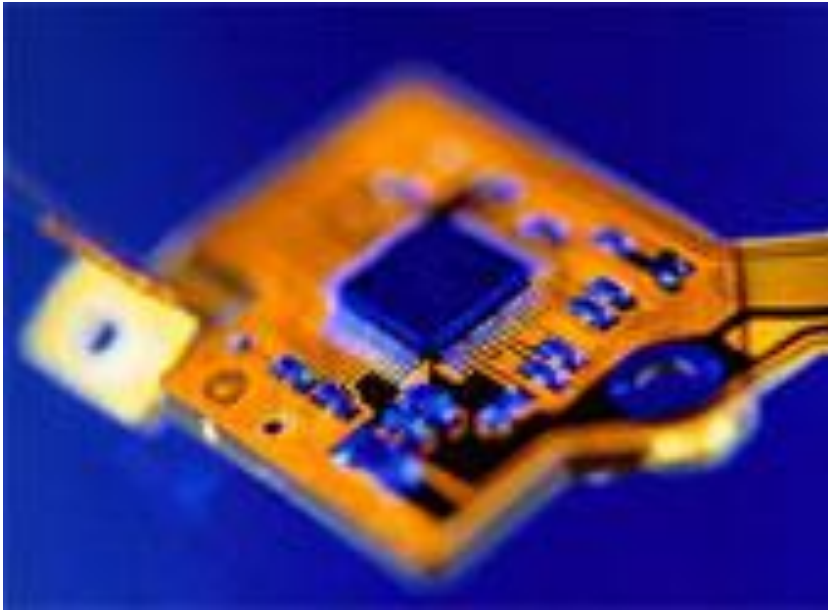

# Community



**W**  
EMD



# Conference Sponsors



**Instituto Superior de Economia e Gestão**  
UNIVERSIDADE TÉCNICA DE LISBOA



# Conference Structure



António Bob dos Santos

Advisor to the Cabinet of the National Coordinator of the Lisbon Strategy and the Technological Plan

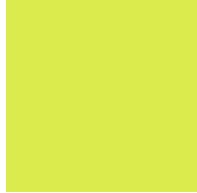

Soumodip Sarkar

Associate Professor of the Department of Management, University of Évora



Alexandra Fezer

Project Manager Security Steinbeis-Europe-Zentrum



# International Panel

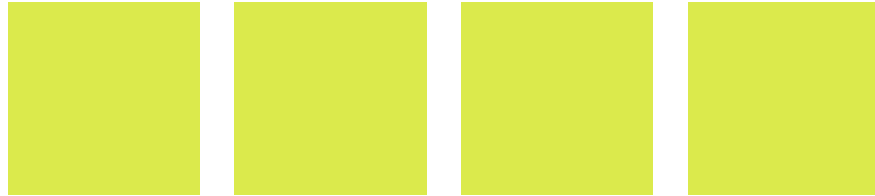

*15 minutes each*

**Technology driven Innovation** Klaus Rischka, Fraunhofer Institut, Bremen

**Innovation as a Mind Set** Claudia Goya, Business and Marketing Officer of Microsoft Portugal

**Chinese Indigenous Innovation** Fernanda Ilhéu – General Secretary of the Portuguese-Chinese Chamber of Commerce and Industry

**Social Innovation** - the power of social entrepreneurs to provoke systemic change Maria Calvo, Director Ashoka Spain



# Conference Structure

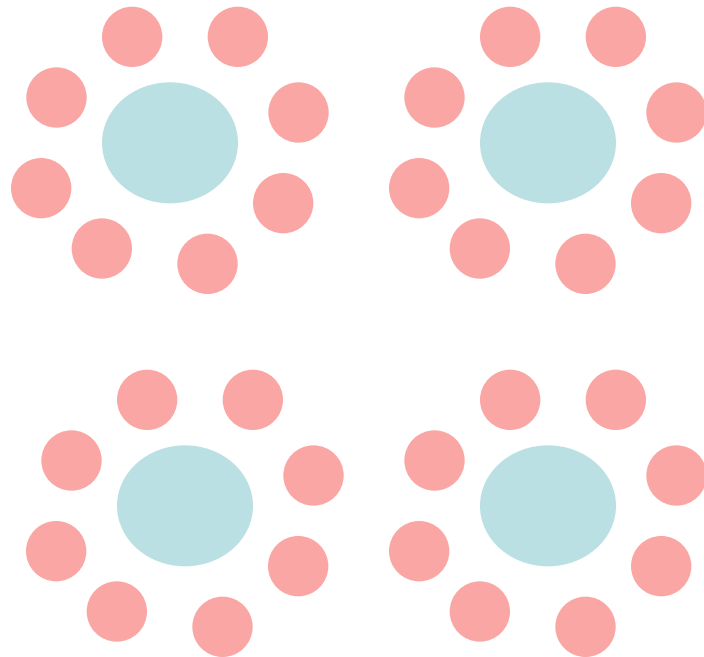

Lunch

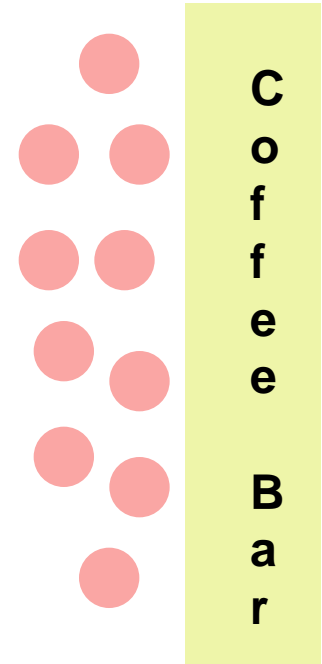

# 4 Speakers' Corner

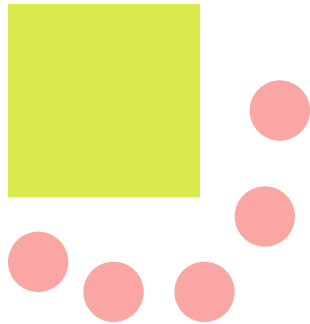

45 minutes

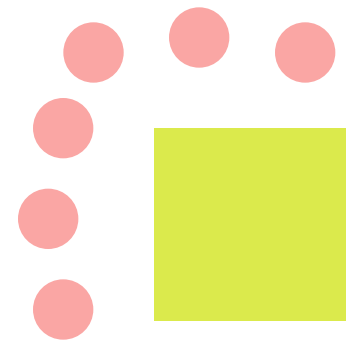
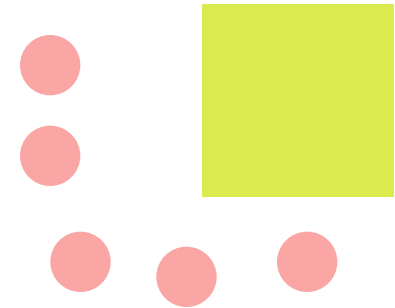

# Networking break

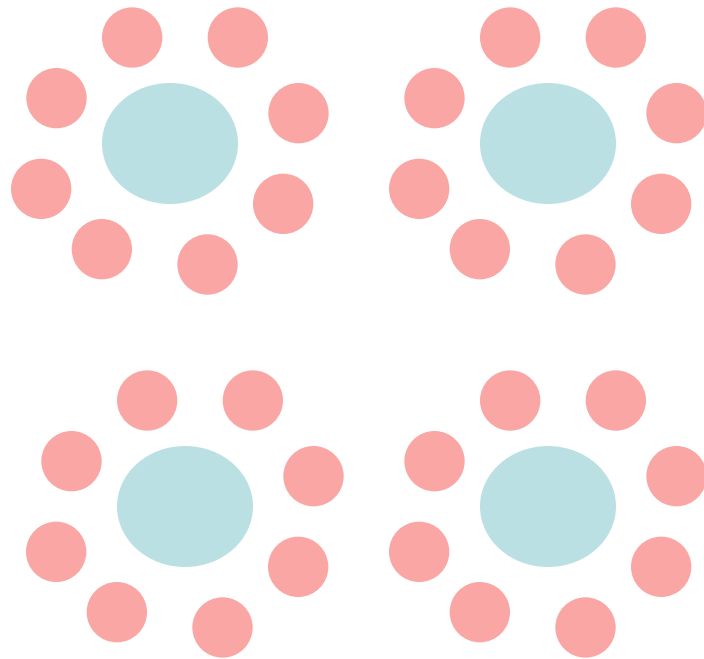

30 min

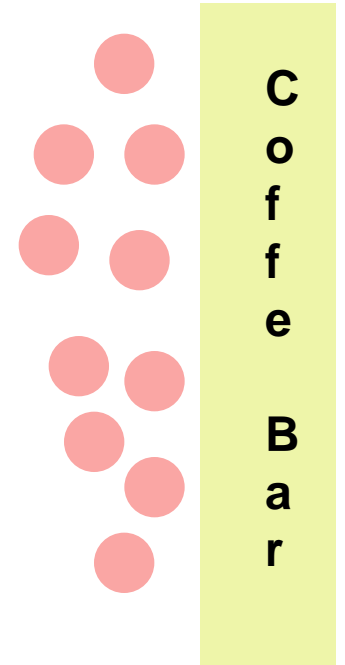

# Portuguese Panel



*Moderator:*  
*Frederico Dinis - Inovar.te*  
*15 minutes*

## **Business Driven Innovative Solutions in Portugal**

Rui Campos Guimarães - CEO of COTEC Portugal

## **Developing New Products: Men and Women's Perspectives**

Isabel Cantista - Professor of AESE

## **Entrepreneurs: Sales & Marketing**

Ana Paula Reis - CEO & Founder of SelPlus

## **Social Driven: Change of Behaviour for a Better Society**

Isabel Jonet - Chairman of Banco Alimentar Contra a Fome



# 4 Speakers' Corner

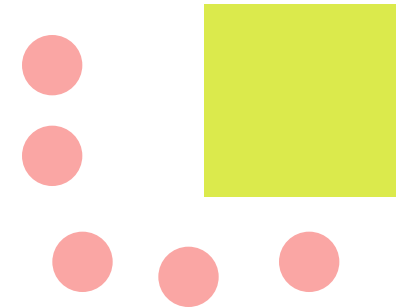
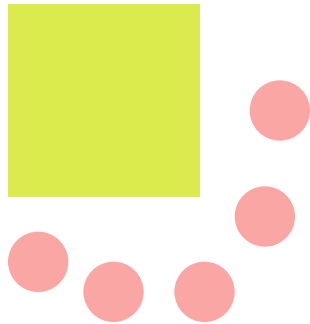

45 minutes

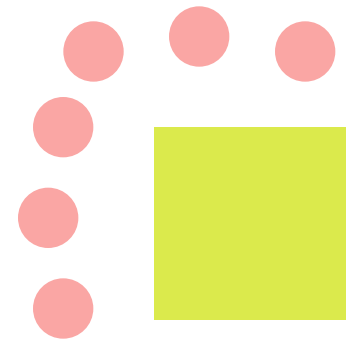

# Final

**Innovation Europe**  
**Make Innovations Work**  
Marcus Gottschalk

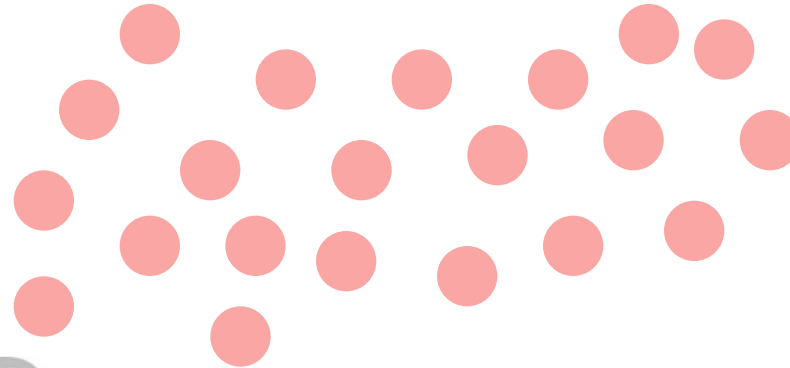

# The End

18.30 h

